

RANGE COMPOSITION

N 900: a range of over 150 models for the professional caterer designed to guarantee the highest level of performance, reliability, energy saving, safety standards and ergonomic operation. These concepts are reflected in the total modularity of the range that ensures innumerable configurations, either free-standing, bridged or cantilever. N900 demonstrates how advanced technology can satisfy the needs of the professional caterer. The models detailed on this sheet are 2 burners gas ranges on gas or electric oven with stainless steel grids.



200102

N 900

4 BURNERS GAS RANGES - TOWN GAS **ZANUSSI** PROFESSIONAL

FUNCTIONAL AND CONSTRUCTION FEATURES

- ◆ Burners with optimized combustion interchangeable on site, flame failure device and protected pilot light:
- 60 mm burners with continuous

- power regulation from 1,5 to 6 kW.
- 100 mm burners with continuous power regulation from 2,2 to 10 kW
- ◆ Manual ignition of the top burners and piezo ignition for the oven
- ◆ Electric oven with switch knob to control top and bottom heating elements. Oven thermostat with temperature markings in °C

- adjustable from 110° to 285°C.
- ◆ Gas oven with stainless steel burners, self-stabilizing flame positioned beneath the base plate and a thermostat adjustable from 120° to 280°C.

TECHNICAL DATA CHARACTERISTICS	MODELS	
	NCFG800T 200116	NCFGE800T 200144
Power supply	Gas	Gas/Electric
External dimensions - mm		
width	800	800
depth	900	900
height	850	850
height adjustment	50	50
Oven cavity - mm		
width	575	575
depth	700	700
height	300	300
Oven		
temperature min-max - °C	120, 280	110, 285
heat input - kW	8,5	6
Back burner dimensions - mm	Ø 60, Ø 100	Ø 60, Ø 100
Back burners power - kW	5,5, 7,5	6, 10
Front burners dimension - mm	Ø 60, Ø 60	Ø 60, Ø 60
Front burners power - kW	5,5, 5,5	6, 6
Net weight - kg.	155	155
Supply voltage		400 V, 3N, 50/60
Town gas	●	●
INCLUDED ACCESSORIES		
2/1 GN CHROME GRID	1	1

- ◆ Worktop in 20/10 stainless steel. Front and side panels in stainless steel with Scotch Brite finish.
- ◆ All models have right-angled side edges to allow flush-fitting joins between units eliminating gaps and possible dirt traps.
- ◆ Stainless steel oven chamber with 3 levels of runners to accommodate 2/1GN shelves.
- ◆ Ribbed, cast-iron oven base plate.
- ◆ Inside door panel in stainless steel
- ◆ Stainless steel feet adjustables up to a height of 50 mm.
- ◆ Handles on the oven in stainless steel.
- ◆ Grids in stainless steel are washable in a dishwasher.
- ◆ Main connections can be via the base of the unit.
- ◆ All models provided with service duct to facilitate installation
- ◆ All gas appliances are supplied for use with natural gas, with LPG conversion jets supplied as standard.
- ◆ The special design of the control knob system guarantees against water infiltration.
- ◆ All models can be installed on cantilever system.
- ◆ IPX5 water protection.

OPTIONAL ACCESSORIES ACCESSORIES	MODELS	
	NCFG800T 200116	NCFG800T 200144
2 CAST IRON PLATE BARS FOR EL.COOK.TOP		206056
2 PANELS FOR SERVICE DUCT (BACK TO BACK)	206202	206202
2 PANELS FOR SERVICE DUCT (SINGLE INST.)	206181	206181
2 SIDE COVERING PANELS FOR TOP-D=900MM	206278	206278
2 SIDE COVERING PANELS H=700 D=900	206134	206134
2 SIDE KICKING STRIPS	206180	206180
2 SIDE KICKING STRIPS F.CONCRETE INSTAL.	206157	206157
2/1 GN CHROME GRID	164250	164250
4 FEET FOR CONCRETE INSTALLATION	206210	206210
4 WHEELS (2 WITH BRAKE)	206188	206188
CHIMNEY UPSTAND 800MM	206304	206304
DRAUGHT DIVERTER WITH 150 MM DIAMETER	206132	206132
FLUE CONDENSER FOR 1 MODULE DIAM.150MM	206246	206246
FRONT.KICK.STRIP F.CONCRETE INST.1000 MM	206150	206150
FRONT.KICK.STRIP F.CONCRETE INST.1200 MM	206151	206151
FRONT.KICK.STRIP F.CONCRETE INST.1600 MM	206152	206152
FRONT.KICK.STRIP F.CONCRETE INST.200 MM	206146	206146
FRONT.KICK.STRIP F.CONCRETE INST.400 MM	206147	206147
FRONT.KICK.STRIP F.CONCRETE INST.800 MM	206148	206148
FRONTAL HANDRAIL 1200 MM	206191	206191
FRONTAL HANDRAIL 1600 MM	206192	206192
FRONTAL HANDRAIL 400 MM	206166	206166
FRONTAL HANDRAIL 800 MM	206167	206167
FRONTAL KICKING STRIP 1000 MM	206177	206177
FRONTAL KICKING STRIP 1200 MM	206178	206178
FRONTAL KICKING STRIP 1600 MM	206179	206179
FRONTAL KICKING STRIP 200 MM	206174	206174
FRONTAL KICKING STRIP 400 MM	206175	206175
FRONTAL KICKING STRIP 800 MM	206176	206176
JUNCTION SEALING KIT	206086	206086
LARGE HANDRAIL(PORIONING SHELF)400 MM	206185	206185
LARGE HANDRAIL(PORIONING SHELF)800 MM	206186	206186
MATCHING RING FOR FLUE CONDENSER 150DIAM	206133	206133
PAIR OF CAST IRON GRIDS	206208	
PAIR OF COVERING STRIPS FOR END ELEMENTS	206234	206234
PRESSURE REGULATOR FOR GAS UNITS	927225	927225
S/S GRID FOR DOUBLE BURNER-900 LINE	206298	206298
SIDE HANDRAIL-RIGHT/LEFT HAND	206165	206165
SINGLE BURNER RIBBED PLATE	206172	206172
SINGLE BURNER SMOOTH PLATE	206171	206171
SINGLE BURNER(6KW/RADIANT PLATE-900 LINE	206170	206170
STAND/SUPPORT 400 MM	206183	206183
STAND/SUPPORT 800 MM	206184	206184
SUPPORT FOR "BRIDGE" SYSTEM 1000 MM	206138	206138
SUPPORT FOR "BRIDGE" SYSTEM 1200 MM	206139	206139
SUPPORT FOR "BRIDGE" SYSTEM 1400 MM	206140	206140
SUPPORT FOR "BRIDGE" SYSTEM 1600 MM	206141	206141
SUPPORT FOR "BRIDGE" SYSTEM 400 MM	206154	206154
SUPPORT FOR "BRIDGE" SYSTEM 800 MM	206137	206137
WATER COLUMN EXTENSION FOR 900 LINE	206290	206290
WATER COLUMN WITH SWIVEL ARM	206288	206288



www.zanussiprofessional.com

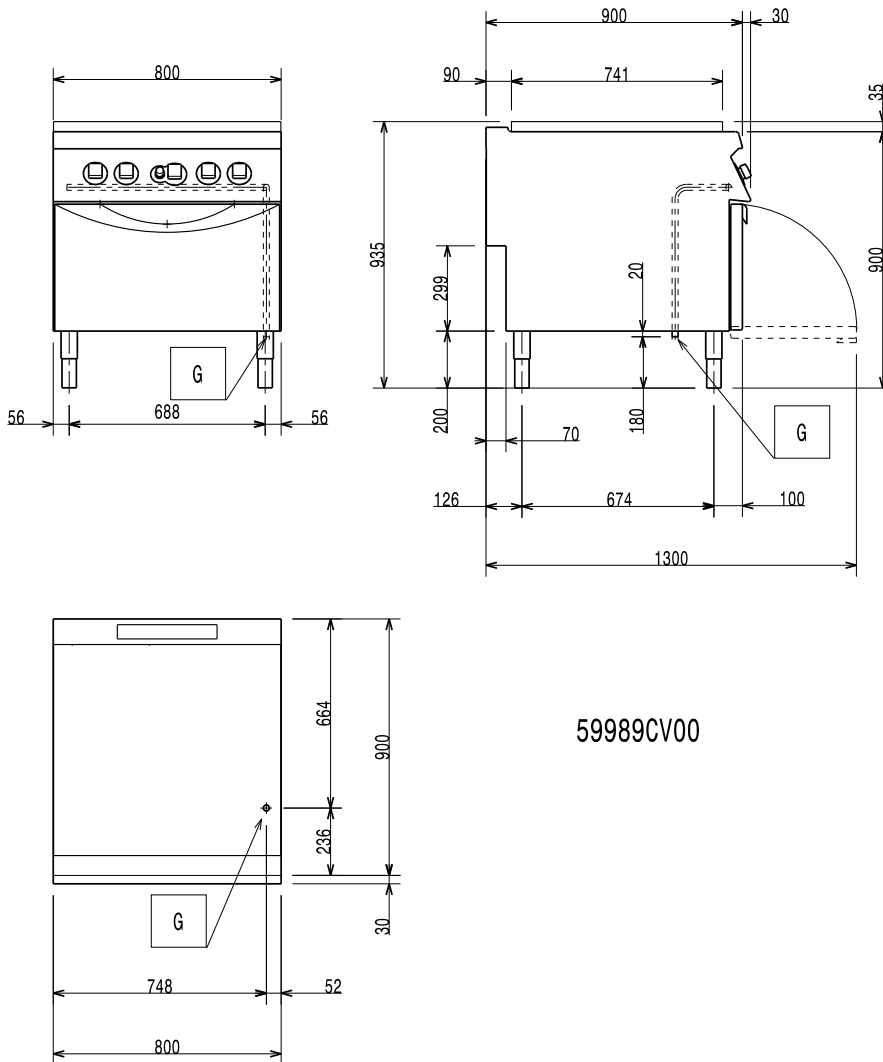

59989CV00

LEGEND

G - Gas connection

NCFG800T
200116
1/2"



www.zanussiprofessional.com

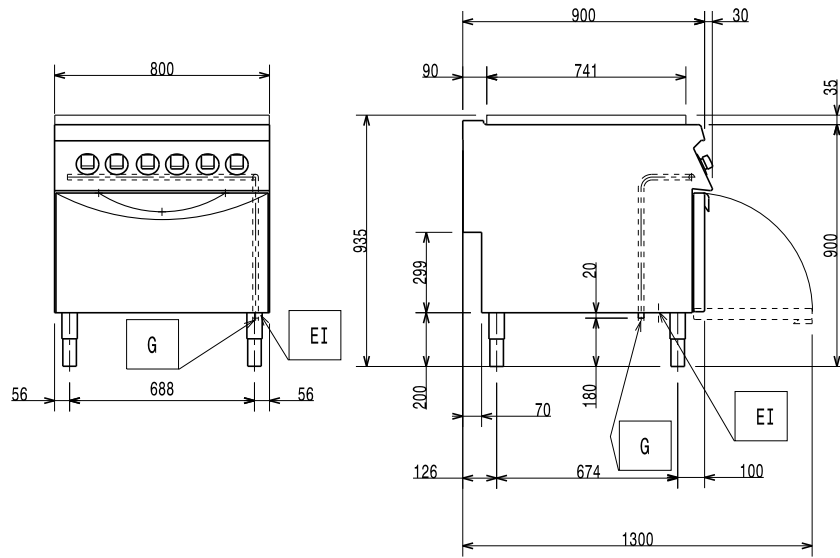

59989D500

LEGEND

	NCFGE800T 200144
EI - Electrical connection	400 V, 3N, 50/60
G - Gas connection	1/2"



www.zanussiprofessional.com