

**Modular Cooking Range Line
ECO 70 One Well Electric
Fryer Top 12 liter**

ITEM # _____

MODEL # _____

NAME # _____

SIS # _____

AIA # _____

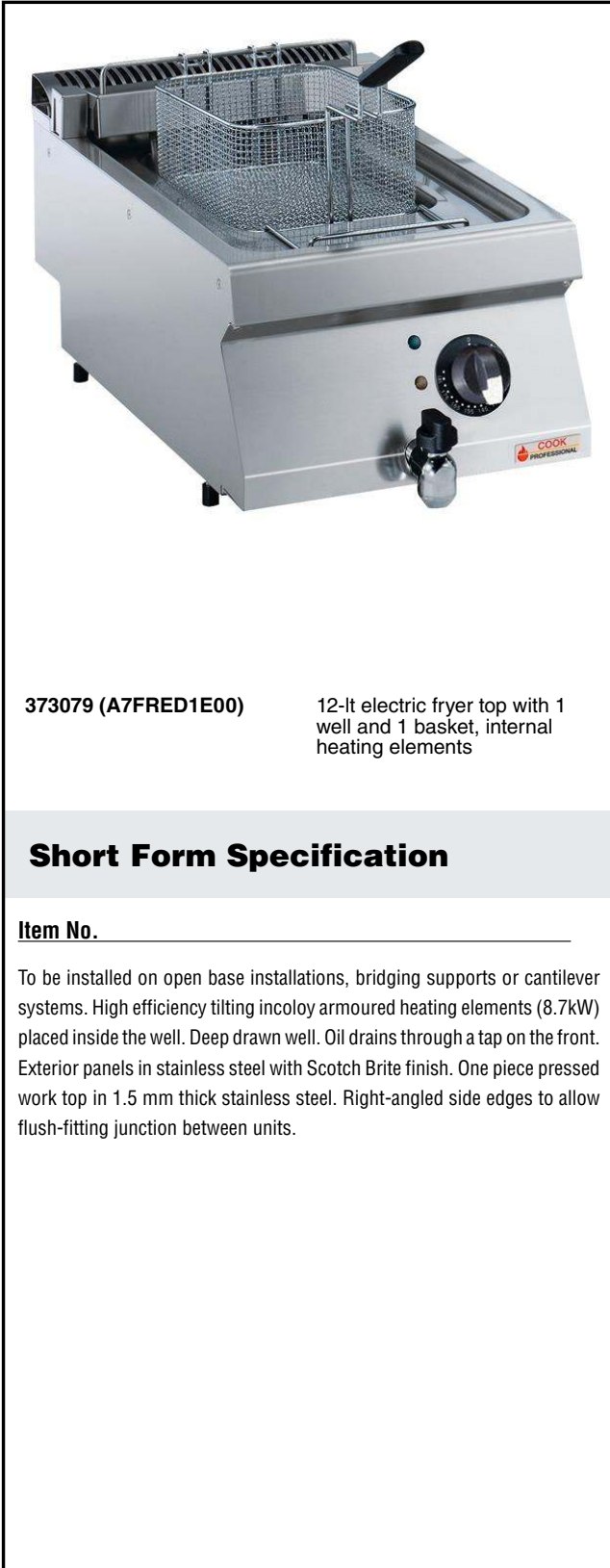

373079 (A7FRED1E00)

12-lt electric fryer top with 1 well and 1 basket, internal heating elements

Short Form Specification

Item No. _____

To be installed on open base installations, bridging supports or cantilever systems. High efficiency tilting incoloy armoured heating elements (8.7kW) placed inside the well. Deep drawn well. Oil drains through a tap on the front. Exterior panels in stainless steel with Scotch Brite finish. One piece pressed work top in 1.5 mm thick stainless steel. Right-angled side edges to allow flush-fitting junction between units.

Main Features

- Unit to be mounted on open base cupboards, bridging supports or cantilever systems.
- Thermostatic regulation of oil temperature up to a maximum of 185 °C.
- Overheat protection thermostat as standard on all units.
- Oil drains through a tap positioned on the front the well.
- All major compartments located in front of unit for ease of maintenance.
- IPX 4 water protection.

Construction

- All exterior panels in Stainless Steel with Scotch Brite finishing.
- One piece pressed 1.5 mm work top in Stainless steel.
- Model has right-angled side edges to allow flush fitting joints between units, eliminating gaps and possible dirt traps.
- Interior of well with rounded corners for ease of cleaning.

APPROVAL: _____

Included Accessories

- 1 of Basket for 12lt electric fryer tops PNC 921629

Optional Accessories

- Junction sealing kit PNC 206086
- Support for bridge type installation, 800mm PNC 206137
- Support for bridge type installation, 1000mm PNC 206138
- Support for bridge type installation, 1200mm PNC 206139
- Support for bridge type installation, 1400mm PNC 206140
- Support for bridge type installation, 1600mm PNC 206141
- Support for bridge type installation, 400mm PNC 206154
- Frontal handrail 400 mm PNC 206166
- Frontal handrail 800 mm PNC 206167
- Large handrail (portioning shelf) 400 mm PNC 206185
- Large handrail (portioning shelf) 800 mm PNC 206186
- Frontal handrail 1200 mm PNC 206191
- Frontal handrail 1600 mm PNC 206192
- Right and left side handrails PNC 206240
- Chimney upstand, 400mm PNC 206303
- 2 side covering panels, height 250 mm, depth 700 mm PNC 206320
- Chimney grid net, 400mm PNC 206400
- Basket for 12lt electric fryer tops PNC 921629



Modular Cooking Range Line ECO 70 One Well Electric Fryer Top 12 liter

Front

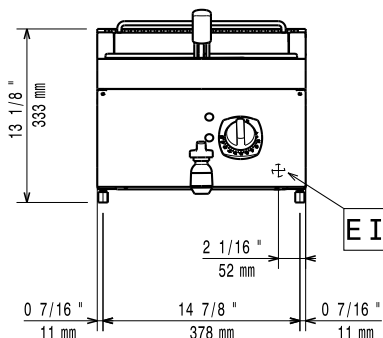

Side

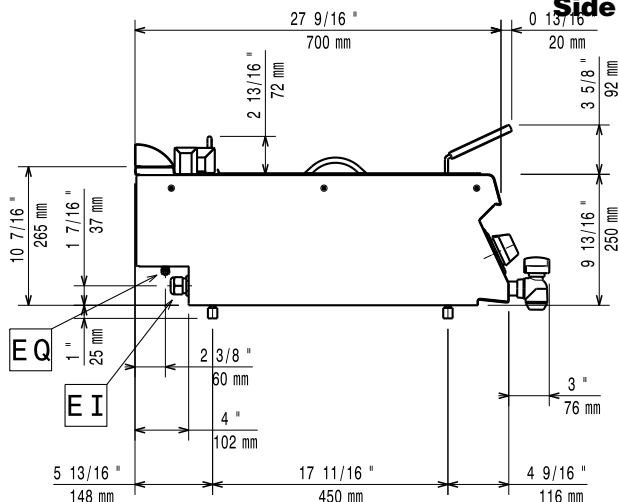

EI = Electrical connection
EQ = Equipotential screw

Top

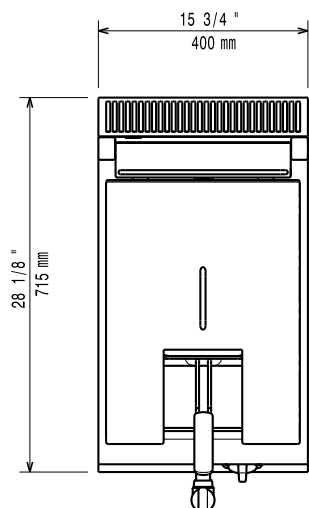

Electric

Supply voltage:
373079 (A7FRED1E00) 380-400 V/3N ph/50/60 Hz
Total Watts: 8.7 kW

Key Information

Usable well dimensions (width): 240 mm
Usable well dimensions (height): 235 mm
Usable well dimensions (depth): 420 mm
Well capacity: 10 lt MIN; 12 lt MAX
Thermostat Range: 105 °C MIN; 185 °C MAX
Shipping weight: 32 kg
Shipping height: 540 mm
Shipping width: 460 mm
Shipping depth: 820 mm
Shipping volume: 0.2 m³

If appliance is set up or next to or against temperature sensitive furniture or similar, a safety gap of approximately 150 mm should be maintained or some form of heat insulation fitted.