

## Modular Cooking Range Line ECO 70 2 Hot Plate Electric Infrared Cooking Top Range

ITEM # \_\_\_\_\_

MODEL # \_\_\_\_\_

NAME # \_\_\_\_\_

SIS # \_\_\_\_\_

AIA # \_\_\_\_\_



373024 (A7IRED2000)

2-zone (2,2 kW each) infrared cooking top

### Short Form Specification

Item No. \_\_\_\_\_

Ceramic glass top cooking surface 6 mm thick, lying flush to the stainless steel frame for smooth pan movement and easier cleaning. Completely sealed infrared cooking top surface to prevent liquid infiltration. Exterior panels in stainless steel with Scotch Brite finish. One piece pressed work top in 1.5 mm thick stainless steel. Right-angled side edges to allow flush-fitting junction between units.

### Main Features

- Ceramic glass top cooking surface with 2 infrared heating zones 6 mm thick.
- The circular concentric heating sections measuring 230 mm give uniform heat also to the largest pan.
- The cooking top is sealed to prevent infiltration inside the unit.
- Warning light to indicate residual surface heat.
- Immediate heat transfer from cooking top to pan.
- Low heat dissipation to the kitchen.
- Energy regulation of each zone.
- Heating via ultra high powered heating elements.
- The smooth glass-ceramic surface can be quickly and easily cleaned, thus providing maximum hygiene.
- IPX 4 water protection.

### Construction

- All exterior panels in Stainless Steel with Scotch Brite finishing.
- One piece pressed 1.5 mm work top in Stainless steel.
- Model has right-angled side edges to allow flush fitting joints between units, eliminating gaps and possible dirt traps.

### Optional Accessories

- Junction sealing kit  PNC 206086
- Support for bridge type installation, 800mm  PNC 206137
- Support for bridge type installation, 1000mm  PNC 206138
- Support for bridge type installation, 1200mm  PNC 206139
- Support for bridge type installation, 1400mm  PNC 206140
- Support for bridge type installation, 1600mm  PNC 206141
- Support for bridge type installation, 400mm  PNC 206154
- Frontal handrail 400 mm  PNC 206166
- Frontal handrail 800 mm  PNC 206167
- Large handrail (portioning shelf) 400 mm  PNC 206185
- Large handrail (portioning shelf) 800 mm  PNC 206186
- Frontal handrail 1200 mm  PNC 206191
- Frontal handrail 1600 mm  PNC 206192
- Right and left side handrails  PNC 206240
- Water column with swivel arm (water column extension not included)  PNC 206289
- Water column extension  PNC 206291

APPROVAL: \_\_\_\_\_



## Modular Cooking Range Line ECO 70 2 Hot Plate Electric Infrared Cooking Top Range

- Chimney upstand, 400mm PNC 206303
- 2 side covering panels, height 250 mm, depth 700 mm PNC 206320
- Chimney grid net, 400mm PNC 206400



**Modular Cooking Range Line  
ECO 70 2 Hot Plate Electric Infrared Cooking Top Range**

The company reserves the right to make modifications to the products without prior notice. All information correct at time of printing.

2018.06.14

# Modular Cooking Range Line ECO 70 2 Hot Plate Electric Infrared Cooking Top Range

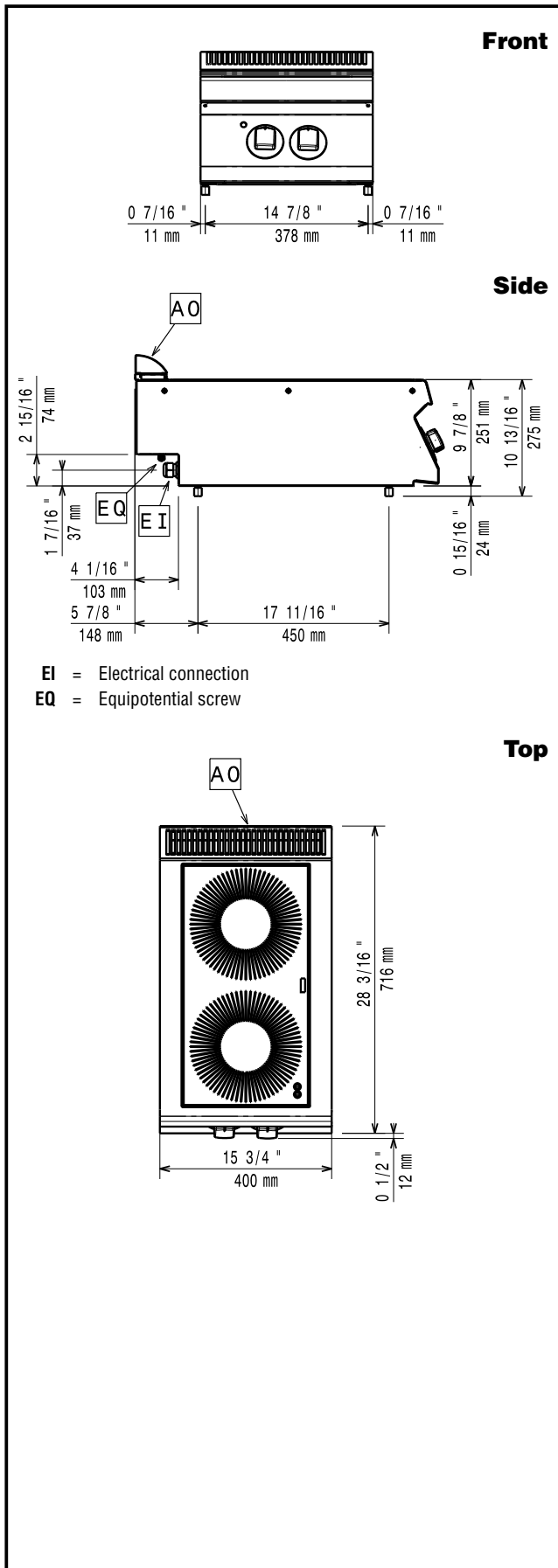

## Electric

Supply voltage:

373024 (A7IRED2000)

380-400 V/3N ph/50/60 Hz

Total Watts:

4.4 kW

## Key Information

Front Plates dimensions: Ø 230

Back Plates dimensions: Ø 230

Shipping weight: 35 kg

Shipping height: 540 mm

Shipping width: 460 mm

Shipping depth: 820 mm

Shipping volume: 0.2 m<sup>3</sup>

If appliance is set up or next to or against temperature sensitive furniture or similar, a safety gap of approximately 150 mm should be maintained or some form of heat insulation fitted.