

Digital Cabinets 2 Half Door Dual Digital Refrigerator, 670lt (0/0) - UK Plug

ITEM # _____

MODEL # _____

NAME # _____

SIS # _____

AIA # _____



727361 (REX72HDRG)

2-half door, dual temperature refrigerator 670lt, 0/+6°C / 0/+6°C, digital, AISI 304 - UK

Short Form Specification

Item No. _____

Two half door refrigerator with internal and external structure in 304 AISI stainless steel; external back panel in galvanized steel and bottom panel in anti-corrosive material. Digital control with cabinet temperature display and setting and manual activation of defrost cycle. Fully compliant HACCP digital controls include visible alarms. Optimized back to front forced air flow provides even temperature distribution and fast cooling in any conditions. Fitted with 75 mm-thick cyclopentane insulating foam. On-site reversible door features lock and door microswitch to switch off the fan when the door is opened. Hidden evaporator to guarantee higher storage capacity and less corrosion problems. Built-in refrigeration unit; ventilated operation; automatic defrost and evaporation of defrost water. Dual operating temperature: 0/+6 °C 0/+6 °C. For ambient temperatures up to 43 °C. CFC and HCFC free. R134a gas in refrigeration circuit.

Supplied with n. 3x2/1GN Rilsan coated grids and n. 3 sets of 2 stainless steel grid runners. Mounted on wheels and equipped with UK Plug.

Main Features

- Automatic defrost.
- Large storage area suitable to contain 2/1 GN grids or shelves on anti-tilt runners.
- Cabinet fitted with up to 75 mm thickness of cyclopentane insulation for best insulating performance with 100% environmental protection (thermal conductivity: 0,020 W/m*K).
- Hidden evaporator thus guaranteeing higher storage capacity and less corrosion problems.
- Automatic evaporation of the defrosting water by hot gas on the top for energy saving.
- Dual temperature type: 0 +6 °C/ 0 +6 °C.
- Internal structure with numerous charging positions available to host grids, ensuring higher net capacity and a greater storage space.
- 60 mm-thick insulation covering the evaporator can be easily removed with a single operation.
- Removable triple-chamber balloon magnetic gasket to improve insulation and reduce energy consumption and ease of cleaning
- Rilsan coated grids for improved protection.
- Right hinged two 1/2 doors.
- Optimized back to front forced air flow provide even temperature distribution and fast cooling in any conditions.
- Digital control with cabinet temperature display and setting and manual activation of defrost cycle. Fully compliant HACCP digital controls include visible alarms.
- Tropicalized unit (43°C ambient temperature).
- This appliance is intended for use in ambient temperatures up to 40°C.

Construction

- Interior base with rounded corners, pressed from a single sheet.
- Mounted on wheels.
- Refrigerant type: R134a.
- The rounded internal corners, the easily removable runners and grids allow for ease of cleaning and high hygiene standards.
- CFC and HCFC-free insulation.
- Easy access to the main components for maintenance.
- Stainless steel runners and supports easily disassembled.
- Door switch stops the fan when door is opened to avoid cold air exiting the cell, thus saving energy.
- Anti-corrosion bottom avoids any damage that may be caused to the cabinet by aggressive detergents employed to clean the floors.
- Doors are self-closing and can be fully opened up to 180°.
- Lockable door.
- Delivered with UK plug.

Included Accessories

- 3 of Grey rilsan grid with 2 runners, GN PNC 881020 2/1
- 1 of 4 small swivelling wheels, 2 with PNC 881035 brake, diam 50 mm, not for remote models

APPROVAL: _____

Optional Accessories

- 2 stainless steel runners for refrigerated cabinets - (Marine) PNC 880242
- 2 stainless steel runners for refrigerated cabinets - (Marine) PNC 880248
- Pedal opening for cabinets PNC 880324
- Plastic container with false bottom, GN 1/1 PNC 880705
- 4 swivelling wheels (2 with brake) for refrigerators, diam 125 mm, NOT for glass door and remote models PNC 881002
- Grey rilsan grid, GN 2/1 PNC 881004
- AISI 304 stainless steel grid, GN 2/1 PNC 881016
- AISI 304 stainless steel grid with 2 runners, GN 2/1 PNC 881018
- Grey rilsan grid with 2 runners, GN 2/1 PNC 881020
- Set of 2 stainless steel runners for 670/1430lt refrigerators and freezers PNC 881021
- 4 small swivelling wheels, 2 with brake, diam 50 mm, not for remote models PNC 881035
- Perforated shelf, GN 2/1 PNC 881042
- Rilsan steel wire basket h=150mm, GN 1/1 PNC 881043

Digital Cabinets 2 Half Door Dual Digital Refrigerator, 670lt (0/0) - UK Plug

Front

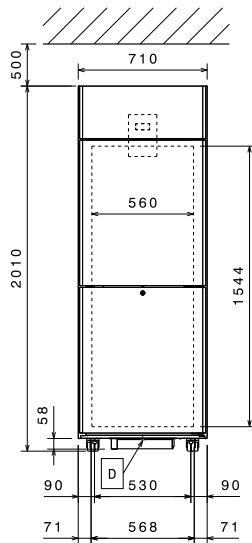

Side

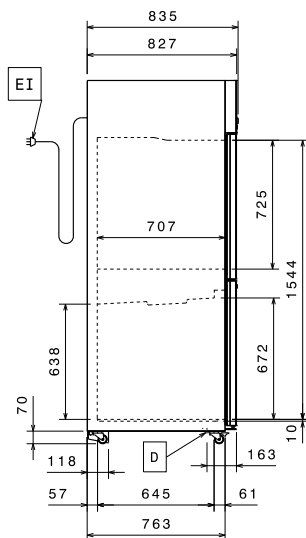

Top

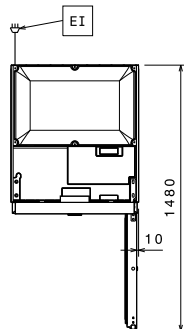

EI = Electrical connection
RI = Refrigerant Inlet
RO = Refrigerant Outlet

Electric

Supply voltage:
727361 (REX72HDRG) 220-230 V/1 ph/50 Hz
Electrical power, max: 0.33 kW

Key Information

Gross capacity 670 lt
Net Volume: 415 lt
Door hinges: 2 Right
External dimensions, Width 710 mm
External dimensions, Height 2010 mm
External dimensions, Depth 835 mm
External dimensions, Depth with Doors Open: 1480 mm
Number and type of doors: 2x1/2 Full
Number and type of grids (included): 3 - GN 2/1
Type of external material: 304 AISI
Type of internal material: 304 AISI
Internal panels material: 304 AISI
Number of positions & pitch: 40; 30 mm

Refrigeration Data

Control type: Digital
Refrigerant type: R404a
Second Unit - Refrigerant Type: R134a
Refrigeration power at evaporation temperature: -10 °C
Operating temperature - First Unit (min-max): 0°C / 6°C
Operating temperature - Second Unit (min-max): 0°C / 6°C
Operating mode: Ventilated

Product Information (EU Regulation 2015/1094)

Energy Class: g
Yearly energy consumption: 1450kWh/year - 3.97kWh/day
Climate class: Heavy Duty (5)
Energy Efficiency Index (EEI): 112.33

Digital Cabinets
2 Half Door Dual Digital Refrigerator, 670lt (0/0) - UK Plug

The company reserves the right to make modifications to the products without prior notice. All information correct at time of printing.

Digital Cabinets 2 Half Door Dual Digital Refrigerator, 670lt (0/0) - UK Plug

EU energy labelling from 1st July 2016

The European energy labelling scheme for professional refrigerators and freezers is based on requirements setting Minimum Energy Performance standards for commercial refrigeration cabinets sold within the EU. These requirements are designed to drive energy efficiency and environmentally friendly approach for professionals. The European energy labelling scheme will apply to all manufacturers and importers who sell and market products within the EU and it is mandatory across Europe.

Important: all products which consume energy above the minimum level will not be able to be sold within the EU from 1 July 2016.

