

Crio Smart 2 Door Digital Freezer, 1430lt (-22/-15) - Remote

ITEM # _____

MODEL # _____

NAME # _____

SIS # _____

AIA # _____



729122 (ARX142FFR)

2-door freezer 1430lt, -22-15°
C, digital, remote, AISI 304

Short Form Specification

Item No. _____

Two full doors freezer with internal and external structure in 304 AISI stainless steel; external back panel in galvanized steel and bottom panel in anti-corrosive material. Digital control with cabinet temperature display and setting and manual activation of defrost cycle. Fully compliant HACCP digital controls include visible alarms. Optimized back to front forced air flow provides even temperature distribution and fast cooling in any conditions. Fitted with 75 mm-thick cyclopentane insulating foam. Door features lock and door microswitch to switch off the fan when the door is opened. Hidden evaporator to guarantee higher storage capacity and less corrosion problems. Remote refrigeration unit; ventilated operation; automatic defrost and evaporation of defrost water. Dual operating temperature: -22/-15°C. For ambient temperatures up to 43 °C. CFC and HCFC free. R404a gas in refrigeration circuit. Supplied with n. 6x2/1GN Rilsan coated grids and n. 6 sets of 2 stainless steel grid runners.

Main Features

- Digital control with cabinet temperature display and setting and manual activation of defrost cycle. Fully compliant HACCP digital controls include visible alarms.
- Large storage area suitable to contain 2/1 GN grids or shelves on anti-tilt runners.
- Optimized back to front forced air flow provide even temperature distribution and fast cooling in any conditions.
- Automatic defrost.
- Internal structure with numerous charging positions available to host grids, ensuring higher net capacity and a greater storage space.
- Cabinet fitted with up to 75 mm thickness of cyclopentane insulation for best insulating performance with 100% environmental protection (thermal conductivity: 0,020 W/ m*K).
- Removable triple-chamber balloon magnetic gasket to improve insulation and reduce energy consumption and ease of cleaning.
- 60 mm-thick insulation covering the evaporator can be easily removed with a single operation.
- Rilsan coated grids for improved protection.
- Hidden evaporator thus guaranteeing higher storage capacity and less corrosion problems.
- Two full doors.
- Freezer model has operating temperatures that can be adjusted from -22 to -15 °C.

Construction

- Constructed from the highest quality AISI 304 Stainless steel.
- Interior base with rounded corners, pressed from a single sheet.
- Stainless steel runners and supports easily disassembled.
- Anti-corrosion bottom avoids any damage that may be caused to the cabinet by aggressive detergents employed to clean the floors.
- Easy access to the main components for maintenance.
- Lockable door.
- Door switch stops the fan when door is opened to avoid cold air exiting the cell, thus saving energy.
- CFC and HCFC-free insulation.
- Mounted on adjustable Stainless steel feet, with castors as an option.
- Doors are self-closing and can be fully opened up to 180°.
- The rounded internal corners, the easily removable runners and grids allow for ease of cleaning and high hygiene standards.
- Remote refrigeration unit.
- Refrigerant type: R404a.

Included Accessories

- 6 of Grey rilsan grid with 2 runners, GN 2/1 PNC 881020

Optional Accessories

- Remote unit -22-15°C for 1430lt refrigerated cabinets PNC 880233

APPROVAL: _____

- 2 stainless steel runners for refrigerated cabinets - (Marine) PNC 880242
- Set of 8 GN1/1 PVC containers for fish PNC 880243
- Spacer for 670 lt and 1430 lt refrigerated cabinets PNC 880248
- Kit integrated HACCP for digital refrigerators (IR33) PNC 880252
- Kit to fit pastry trays (400x600mm) PNC 880333
- Plastic container with false bottom, GN 1/1 PNC 880705
- 4 swivelling wheels (2 with brake) for refrigerators, diam 125 mm, NOT for glass door and remote models PNC 881002
- Grey rilsan grid, GN 2/1 PNC 881004
- AISI 304 stainless steel grid, GN 2/1 PNC 881016
- AISI 304 stainless steel grid with 2 runners, GN 2/1 PNC 881018
- Grey rilsan grid with 2 runners, GN 2/1 PNC 881020
- Set of 2 stainless steel runners for 670/1430lt refrigerators and freezers PNC 881021
- Pedal opening for 1430lt refrigerators PNC 881033
- PVC container with lid and 2 runners, GN 2/1 PNC 881039
- Perforated shelf, GN 2/1 PNC 881042
- Rilsan steel wire basket h=150mm, GN 1/1 PNC 881043
- 3 grey rilsan central grids for 1430lt (not for glass door) PNC 881044
- Grey rilsan basket+2 runners h=150mm, GN 2/1 PNC 881047
- Kit HACCP EKIS PNC 922166

Front

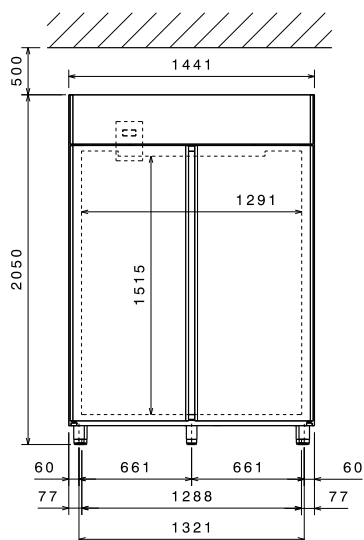

Side

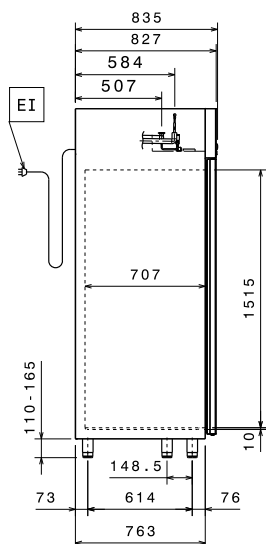

EI = Electrical inlet (power)
RI = Refrigerant Inlet
RO = Refrigerant Outlet

Top

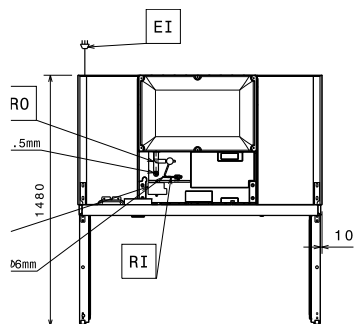

Electric

Supply voltage:	729122 (ARX142FFR)	220-240 V/1 ph/50/60 Hz
Electrical power max.:		0.25 kW
Defrost Power:		0.5 kW
Current consumption:		1 Amps
Plug type:		CE-SCHUKO
Energy consumption (min,default):		0 - 0 kW/h

Key Information:

Gross capacity:	1430 lt
Net Volume:	1135 lt
Door hinges:	1 Left+1 Right
External dimensions, Width:	1441 mm
External dimensions, Height:	2050 mm
External dimensions, Depth:	835 mm
Number and type of doors:	2 Full
Internal Dimensions (depth):	707 mm
Internal Dimensions (height):	1515 mm
Internal Dimensions (width):	1291 mm
Shipping volume:	2.82 m ³
Height adjustment:	0/0 mm
Number and type of grids (included):	6 - GN 2/1

Refrigeration Data

Control type:	Digital
Compressor power:	
Refrigerant type:	R404a
GWP Index:	3922
Refrigeration power:	0 W
Refrigeration power at evaporation temperature:	-30 °C
Refrigerant weight:	0 g
Min/Max internal humidity:	
Operating temperature min.:	-22 °C
Operating temperature max.:	-15 °C
Operating mode:	Ventilated

Product Information (EU Regulation 2015/1094)

Energy Class:	
Yearly and daily energy consumption:	
Climate class:	
Energy Efficiency Index (EEI):	