

Crio Line HP Refrigerated Counter - 440lt, 3-Door, Upstand

ITEM # _____

MODEL # _____

NAME # _____

SIS # _____

AIA # _____



712028 (AH3H3AAA)

3-door refrigerated counter
440lt, -2+10°C, AISI 304, with
upstand

Short Form Specification

Item No. _____

External and internal in AISI 304 stainless steel, galvanized back panel, bottom AISI 430. Extra insulation: 90mm body insulation to minimize energy dispersion, fitted with integrated rear upstand mm100h. N. 3 full doors. Built-in refrigeration unit. Ventilated operating mode. Evaporator. Electronic microprocessor control with external digital temperature display. Automatic defrost. Operating temperature: -2+10° C. CFC and HCFC free. R290 gas in refrigeration circuit. Gas in foam: Cyclopentane.
Supplied with 1 grid for each compartment (no grid for compartment with drawers).

Main Features

- Preservation performances and temperature uniformity within the cell guaranteed at 5-HEAVY DUTY (40°C) working conditions according to EN16825:2016 test protocol.
- Adjustable temperature range from -2 °C to +10 °C to suit meat, fish and dairy storage requirements.
- Large digital white-digit display with humidity selection button (3 preset level), internal temperature display and setting, manual activation of defrost cycle and turbo frost cycle (to rapidly cool warm loads).
- Equipped with Airflow system: forced air circulation system for rapid cooling and even temperature distribution within the cell.
- Tropicalized unit (43°C ambient temperature).
- Fitted with 90 mm thickness of cyclopentane insulation for best insulating performance (thermal conductivity: 0,020 W/m*K) and lowest environmental impact (GWP=3).
- 0mm clearance installation space: tower configuration cooling unit guarantee performance with frontal ventilation only; this unique solution allows installation against the wall or side by side with other appliances, even on the cooling unit side to maximize the use of kitchen space.
- IQ Defrost - fully automatic defrost starts only when ice is actually building-up in the evaporator and adapts the defrosting duration to guarantee perfect ice removal while optimizing energy efficiency consumption.
- Combination of doors and drawers to suit any configuration needed, with the possibility to change the configuration on site. Right cooling unit available on request.
- Fully removable cooling unit to facilitate maintenance.
- Frontal and easy access to all components in the cooling unit.
- Fully compliant HACCP digital control: when temperature exceeds critical limits, acoustic and visual alarms are activated. Up to two months of event are kept in memory.
- Anti-tilt runners accept GN 1/1 containers.
- Self closing stainless steel doors (< 90°).
- Certified safety CE requirements.
- Prearranged to fit RS485 port to facilitate connection to a remote computer and integrated HACCP systems.
- Hot gas automatic evaporation of defrost water.
- Hydrocarbon refrigerant gas R290 for the lowest environmental impact (GWP=3) - CFC and HCFC free.

APPROVAL: _____

Construction

- 3 compartments with 3 doors.
- Worktop in AISI 304 Stainless steel with a 50 mm profile.
- If needed, working top can be removed for easier handling during installation (in case of narrow doors).
- Raised rear upstand permits unit to be connected up against the wall for better hygiene.
- Anti-drip profile on stainless steel worktop edge.
- Interior base with rounded corners, pressed from a single sheet.
- Ease of cleaning and high hygiene standards thanks to the rounded internal corners, the easily removable runners, grids and air conveyors.
- Removable triple-chamber balloon magnetic gasket to improve insulation and reduce energy consumption and ease of cleaning.
- Internal structure with 15 charging positions (3 cm pitch) available to host GN 1/1 grids, ensuring higher net capacity and a greater storage space.
- Internal and external doors, front and side panels and removable worktop in AISI 304 Stainless steel.
- Mounted on stainless steel feet to give 150 mm (-5/+50 mm) clearance for ease of cleaning the floor.
- Built-in refrigeration unit.
- Developed and produced in ISO 9001 and ISO 14001 certified factory.
- Fault code display.
- IP21 protection index.

Included Accessories

- 3 of Kit 1/1 gray rilsan grid and 2 side runners for refrigerated counters PNC 881109

Optional Accessories

- 2x1/2-drawer kit refrigerated counter PNC 881079
- 3x1/3-drawer kit refrigerated counter PNC 881080
- 1/3 and 2/3 bottle drawer kit for refrigerated counters PNC 881081
- 1/1GN gray rilsan grid for refrigerated counters PNC 881107
- 2 side runners for 1/1 GN ecostore refrigerated counters PNC 881108
- Kit 1/1 gray rilsan grid and 2 side runners for refrigerated counters PNC 881109
- 1/1 GN plastic container, H=65 mm PNC 881110
- 1/1 GN plastic container, H=100 mm PNC 881111
- 1/1 GN plastic container, H=150 mm PNC 881112

Front

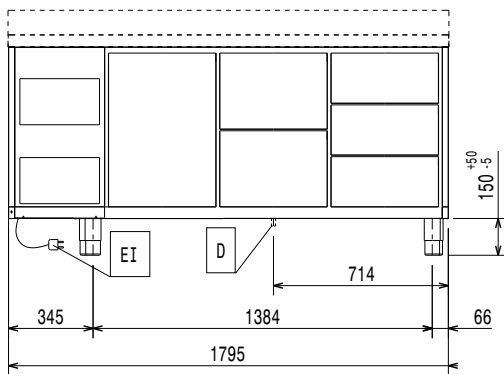

Side

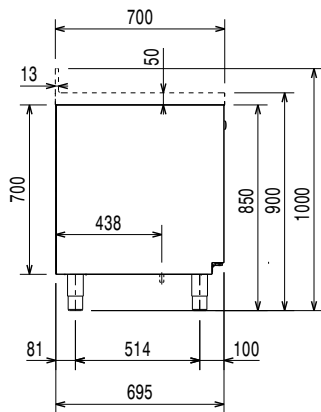

EI = Electrical inlet (power)

Top

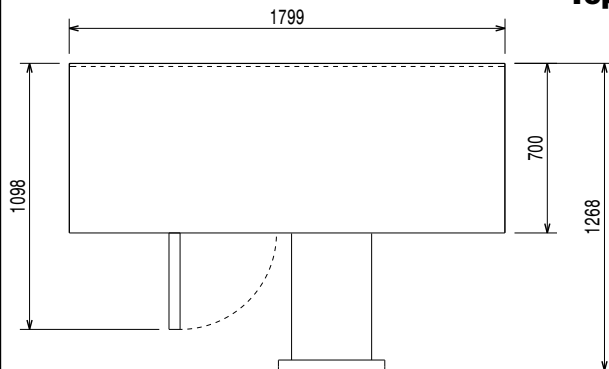

Electric

Supply voltage:	712028 (AH3H3AAA)	220-240 V/1 ph/50 Hz
Electrical power max.:		0.25 kW
Defrost Power:		0.22 kW
Current consumption:		1.8 Amps
Plug type:		CE-SCHUKO

Key Information:

Gross capacity:	440 lt
Net Volume:	310 lt
Door hinges:	1 Left+2 Right
External dimensions, Width:	1799 mm
External dimensions, Height:	1000 mm
External dimensions, Depth:	700 mm
Internal Dimensions (depth):	560 mm
Internal Dimensions (height):	550 mm
Internal Dimensions (width):	1252 mm
Net weight:	132 kg
Shipping volume:	1.64 m ³
Depth with doors open:	1110 mm
Height adjustment:	-5/50 mm

Refrigeration Data

Control type:	Digital
Compressor power:	1/4 hp
Refrigerant type:	R290
GWP Index:	3
Refrigeration power:	320 W
Refrigeration power at evaporation temperature:	-10 °C
Refrigerant weight:	70 g
Min/Max internal humidity:	40/85
Operating temperature min.:	-2 °C
Operating temperature max.:	10 °C
Operating mode:	Ventilated

Product Information (EU Regulation 2015/1094)

Energy Class:	A
Yearly and daily energy consumption:	560kWh/year - 1.53kWh/24h
Climate class:	Heavy Duty (5)
Energy Efficiency Index (EEI):	21.69

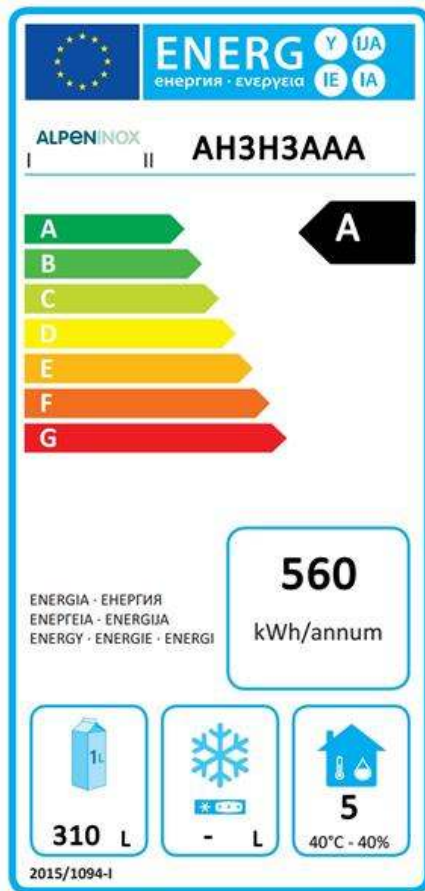

EU energy labelling from 1st July 2016

The European energy labelling scheme for professional refrigerators and freezers is based on requirements setting Minimum Energy Performance standards for commercial refrigeration cabinets sold within the EU. These requirements are designed to drive energy efficiency and environmentally friendly approach for professionals. The European energy labelling scheme will apply to all manufacturers and importers who sell and market products within the EU and it is mandatory across Europe.

Important: all products which consume energy above the minimum level will not be able to be sold within the EU from 1 July 2016.