

## Crio Line HP Refrigerated Saladette- 440lt, 3-Door

ITEM # \_\_\_\_\_

MODEL # \_\_\_\_\_

NAME # \_\_\_\_\_

SIS # \_\_\_\_\_

AIA # \_\_\_\_\_



712059 (AH3HSAAA)

3-door refrigerated counter, saladette with cut-out for containers, -2+10°C, 440lt, AISI 304

### Short Form Specification

#### Item No. \_\_\_\_\_

External and internal in AISI 304 stainless steel, galvanized back panel. Extra insulation: 90mm body insulation to minimize energy dispersion, fitted with cut-out for n. 6 GN 1/3 containers (not included) and stainless steel lid. N. 3 full doors. Built-in refrigeration unit. Ventilated operating mode. Evaporator. Electronic microprocessor control with external digital temperature display. Automatic defrost. Operating temperature: -2+10°C. CFC and HCFC free. R290 gas in refrigeration circuit. Gas in foam: Cyclopentane.

Supplied with n. 3X1/1GN Rilsan coated grids.

### Main Features

- Adjustable temperature range from -2 °C to +10 °C to suit meat, fish and dairy storage requirements.
- Large digital white-digit display with humidity selection button (3 preset level), internal temperature display and setting, manual activation of defrost cycle and turbo frost cycle (to rapidly cool warm loads).
- Equipped with Airflow system: forced air circulation system for rapid cooling and even temperature distribution within the cell.
- Tropicalized unit (43°C ambient temperature).
- Fitted with 90 mm thickness of cyclopentane insulation for best insulating performance (thermal conductivity: 0,020 W/m\*K) and lowest environmental impact (GWP=3).
- 0mm clearance installation space: tower configuration cooling unit guarantee performance with frontal ventilation only; this unique solution allows installation against the wall or side by side with other appliances, even on the cooling unit side to maximize the use of kitchen space.
- IQ Defrost - fully automatic defrost starts only when ice is actually building-up in the evaporator and adapts the defrosting duration to guarantee perfect ice removal while optimizing energy efficiency consumption.
- Combination of doors and drawers to suit any configuration needed, with the possibility to change the configuration on site. Right cooling unit available on request.
- Fully removable cooling unit to facilitate maintenance.
- Frontal and easy access to all components in the cooling unit.
- Fully compliant HACCP digital control: when temperature exceeds critical limits, acoustic and visual alarms are activated. Up to two months of event are kept in memory.
- Anti-tilt runners accept GN 1/1 containers.
- Self closing stainless steel doors (< 90°).
- Certified safety CE requirements.
- Prearranged to fit RS485 port to facilitate connection to a remote computer and integrated HACCP systems.
- Hot gas automatic evaporation of defrost water.
- Hydrocarbon refrigerant gas R290 for the lowest environmental impact (GWP=3) - CFC and HCFC free.
- Cut-out worktop suitable for 6 GN 1/3 trays.
- Stainless steel lid for non-operating periods.
- No cross-contamination between upper and lower part (nothing will fall in the lower compartment).
- Large front working top (400 mm depth).

APPROVAL: \_\_\_\_\_

### Construction

- 3 compartments with 3 doors.
- Worktop in AISI 304 Stainless steel with a 50 mm profile.
- If needed, working top can be removed for easier handling during installation (in case of narrow doors).
- Anti-drip profile on stainless steel worktop edge.
- Interior base with rounded corners, pressed from a single sheet.
- Ease of cleaning and high hygiene standards thanks to the rounded internal corners, the easily removable runners, grids and air conveyors.
- Removable triple-chamber balloon magnetic gasket to improve insulation and reduce energy consumption and ease of cleaning.
- Internal structure with 15 charging positions (3 cm pitch) available to host GN 1/1 grids, ensuring higher net capacity and a greater storage space.
- Internal and external doors, front and side panels and removable worktop in AISI 304 Stainless steel.
- Mounted on stainless steel feet to give 150 mm (-5/+50 mm) clearance for ease of cleaning the floor.
- Built-in refrigeration unit.
- Developed and produced in ISO 9001 and ISO 14001 certified factory.
- Fault code display.
- IP21 protection index.

### Included Accessories

- 3 of Kit 1/1 gray rilsan grid and 2 side runners for refrigerated counters PNC 881109

### Optional Accessories

- 1/1GN gray rilsan grid for refrigerated counters PNC 881107
- 2 side runners for 1/1 GN ecostore refrigerated counters PNC 881108
- Kit 1/1 gray rilsan grid and 2 side runners for refrigerated counters PNC 881109
- 1/1 GN plastic container, H=65 mm PNC 881110
- 1/1 GN plastic container, H=100 mm PNC 881111
- 1/1 GN plastic container, H=150 mm PNC 881112

**Front**

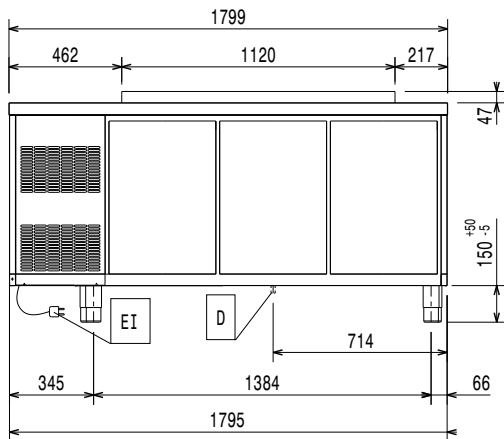

**Side**

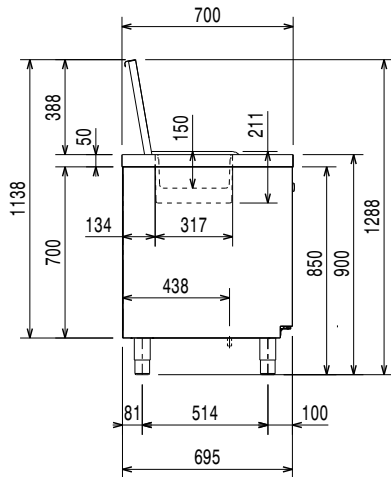

EI = Electrical inlet (power)

**Top**

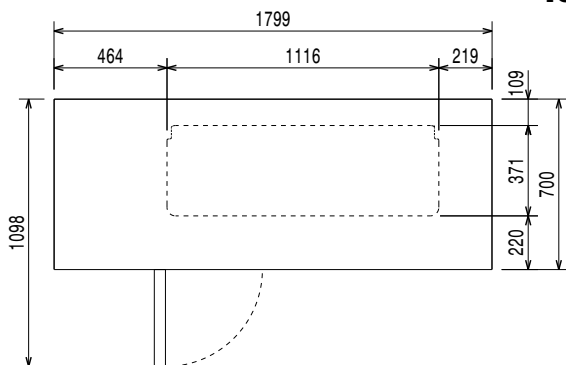

### Electric

<b>Supply voltage:</b>	712059 (AH3HSAAA)	220-240 V/1 ph/50 Hz
<b>Electrical power max.:</b>		0.25 kW
<b>Defrost Power:</b>		
<b>Current consumption:</b>		1.8 Amps
<b>Plug type:</b>		CE-SCHUKO

### Key Information:

<b>Gross capacity:</b>	440 lt
<b>Net Volume:</b>	227 lt
<b>Door hinges:</b>	1 Left+2 Right
<b>External dimensions, Width:</b>	1799 mm
<b>External dimensions, Height:</b>	900 mm
<b>External dimensions, Depth:</b>	700 mm
<b>Internal Dimensions (depth):</b>	560 mm
<b>Internal Dimensions (height):</b>	550 mm
<b>Internal Dimensions (width):</b>	1252 mm
<b>Shipping volume:</b>	1.5 m <sup>3</sup>
<b>Depth with doors open:</b>	1110 mm
<b>Height adjustment:</b>	-5/50 mm

### Refrigeration Data

<b>Control type:</b>	Digital
<b>Compressor power:</b>	1/4 hp
<b>Refrigerant type:</b>	R290
<b>GWP Index:</b>	3
<b>Refrigeration power:</b>	320 W
<b>Refrigeration power at evaporation temperature:</b>	-10 °C
<b>Refrigerant weight:</b>	70 g
<b>Min/Max internal humidity:</b>	40/85
<b>Operating temperature min.:</b>	-2 °C
<b>Operating temperature max.:</b>	10 °C
<b>Operating mode:</b>	Ventilated