

CRIO Line CP 6 Drawer Refrigerated Counter, 420lt (-2/+10)

ITEM # _____

MODEL # _____

NAME # _____

SIS # _____

AIA # _____

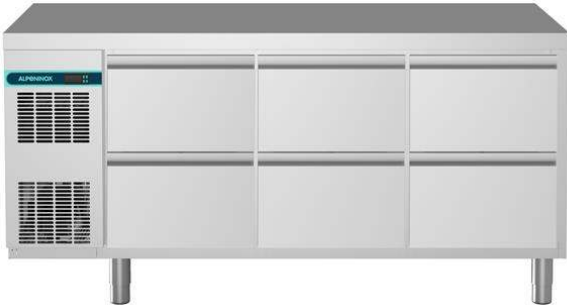

712653 (AJ3RBBBB)

6-drawer refrigerated counter, -2+10°C, AISI 304

Short Form Specification

Item No. _____

Internal and external doors, front and side panels and worktop in 304 AISI stainless steel. N.6x1/2 drawers. Built-in refrigeration unit. Ventilated. Refrigerant R134aa. High-density expanded polyurethane foam, 90 mm in thickness, with cyclopentane injection. Digital control panel. Completely automatic defrosting and automatic evaporation of defrost water obtained by hot gas. Suitable to operate in ambient temperatures up to +43°C. Temperature range: -2+10°C. CFC and HCFC free. Feet in 304 AISI stainless steel, adjustable in height.

Main Features

- Tropicalized unit (43°C ambient temperature).
- IQ Defrost - fully automatic defrost starts only when ice is actually building-up in the evaporator and adapts the defrosting duration to guarantee perfect ice removal while optimizing energy efficiency consumption.
- Large digital white-digit display with humidity selection button (3 preset level), internal temperature display and setting, manual activation of defrost cycle and turbo frost cycle (to rapidly cool warm loads).
- Equipped with Airflow system: forced air circulation system for rapid cooling and even temperature distribution within the cell.
- Fitted with 90 mm thickness of cyclopentane insulation for best insulating performance (thermal conductivity: 0,020 W/m*K) and lowest environmental impact (GWP=3).
- 0mm clearance installation space: tower configuration cooling unit guarantee performance with frontal ventilation only; this unique solution allows installation against the wall or side by side with other appliances, even on the cooling unit side to maximize the use of kitchen space.
- Combination of doors and drawers to suit any configuration needed, with the possibility to change the configuration on site. Right cooling unit available on request.
- Frontal and easy access to all components in the cooling unit.
- Fully compliant HACCP digital control: when temperature exceeds critical limits, acoustic and visual alarms are activated. Up to two months of event are kept in memory.
- Anti-tilt runners accept GN 1/1 containers.
- Self closing stainless steel doors (< 90°).
- Certified safety CE requirements.
- Prearranged to fit RS485 port to facilitate connection to a remote computer and integrated HACCP systems.
- Hot gas automatic evaporation of defrost water.
- Adjustable temperature range from -2 °C to +10 °C to suit meat, fish and dairy storage requirements.

Construction

- Developed and produced in ISO 9001 and ISO 14001 certified factory.
- CFC and HCFC free (ecological refrigerant type: R134a, - gas in foam: cyclopentane).
- Fault code display.
- Interior base with rounded corners, pressed from a single sheet.
- Internal and external doors, front and side panels and removable worktop in AISI 304 Stainless steel.
- Worktop in AISI 304 Stainless steel with a 50 mm profile.
- Built-in refrigeration unit.
- Anti-drip profile on stainless steel worktop edge.
- Removable triple-chamber balloon magnetic gasket to improve insulation and reduce energy consumption and ease of cleaning.
- If needed, working top can be removed for easier handling during installation (in case of narrow doors).
- Mounted on stainless steel feet to give 150 mm (-5/+50 mm) clearance for ease of cleaning the floor.
- Ease of cleaning and high hygiene standards thanks to the rounded internal corners, the easily removable runners, grids and air conveyors.

APPROVAL: _____

- Internal structure with 15 charging positions (3 cm pitch) available to host GN 1/1 grids, ensuring higher net capacity and a greater storage space.
- Extractable cooling unit to facilitate maintenance.
- IP21 protection index.
- Internal dimension of the drawers:
 - models with 2 1/2 drawers: 1st drawer (top drawer) 196x302x521 / 2nd drawer 198x302x521 (HxWxD)
 - models with 3 1/3 drawers: 1st and 2nd drawers (top and central drawer) 99x302x521 / 3rd drawers 103x302x521 (HxWxD)
 - models with 1/3+2/3 drawers: 1st drawer (top drawer) 99x302x521 / 2nd drawer 295x302x521 (HxWxD)

Optional Accessories

- 1/1GN gray rilsan grid for refrigerated counters PNC 881107
- 2 side runners for 1/1 GN ecostore refrigerated counters PNC 881108
- Kit 1/1 gray rilsan grid and 2 side runners for refrigerated counters PNC 881109
- 1/1 GN plastic container, H=65 mm PNC 881110
- 1/1 GN plastic container, H=100 mm PNC 881111
- 1/1 GN plastic container, H=150 mm PNC 881112
- Worktop for ecostore refrigerated counters - 3 compartments PNC 881125
- Worktop and upstand for ecostore refrigerated counters - 3 compartments PNC 881128
- 2-drawer kit refrigerated counters PNC 881179
- 3x -drawer kit for refrigerated counters PNC 881186
- 1/3 and 2/3 bottle drawer kit for refrigerated counters PNC 881187
- Lock for refrigerated counters (3 compartments) - H650 PNC 881189
- Kit 4 wheels, H=100 mm (2 with brakes) for refrigerated counters PNC 881191
- Kit 4 wheels, H=150 mm (2 with brakes) for 2&3 compartment refrigerated counters PNC 881193

Front

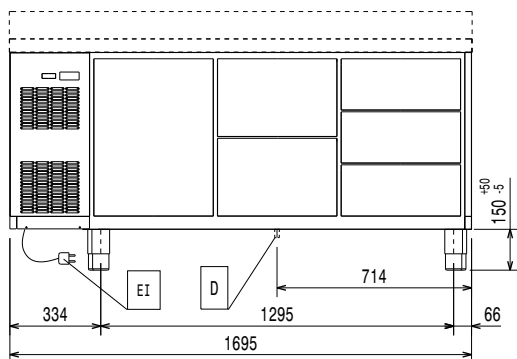

Side

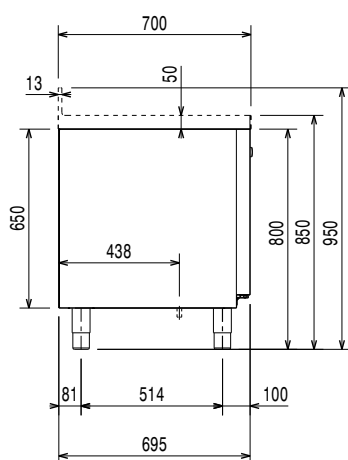

EI = Electrical inlet (power)

Top

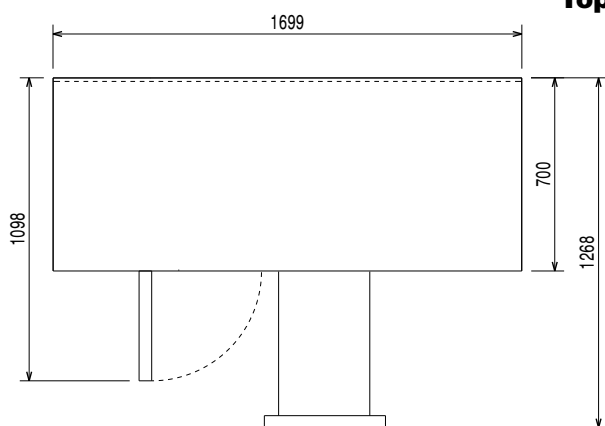

Electric

Supply voltage:

712653 (AJ3RBBBB)

220-240 V/1 ph/50 Hz

Electrical power max.:

0.22 kW

Key Information:

Gross capacity:

Net Volume:

164 lt

External dimensions, Width:

1699 mm

External dimensions, Height:

850 mm

External dimensions, Depth:

700 mm

Noise level:

48 dBA

N° of drawers:

Built-in Compressor and Refrigeration Unit

Refrigeration Data

Compressor power:

0.25 hp

Refrigerant type:

R134a

Refrigeration power:

358 W

Refrigeration power at evaporation temperature:

-10 °C

Refrigerant weight:

120 g

Operating temperature min.:

-2 °C

Operating temperature max.:

10 °C

Operating mode:

Ventilated

Defrost type:

N° defrost in 24 hrs:

Product Information (EU Regulation 2015/1094)

Energy Class:

C

Yearly and daily energy consumption:

835kWh/year - 2.29kWh/24h

Climate class:

Normal duty (cl.4)

Energy Efficiency Index (EEI):

37.81

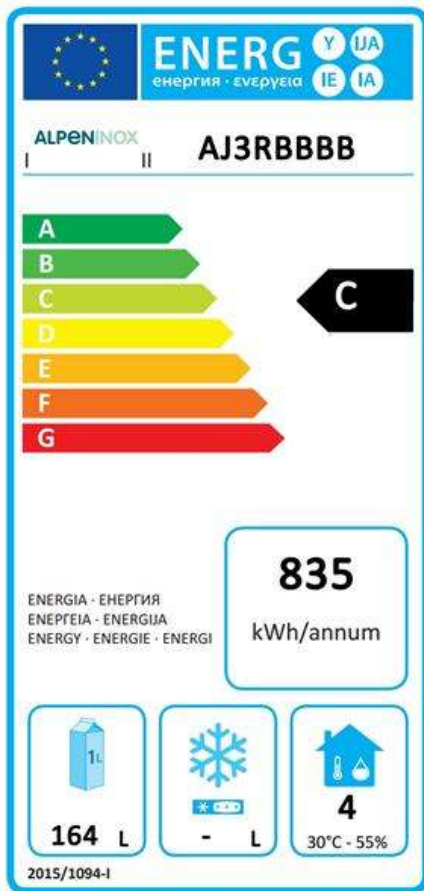

EU energy labelling from 1st July 2016

The European energy labelling scheme for professional refrigerators and freezers is based on requirements setting Minimum Energy Performance standards for commercial refrigeration cabinets sold within the EU. These requirements are designed to drive energy efficiency and environmentally friendly approach for professionals. The European energy labelling scheme will apply to all manufacturers and importers who sell and market products within the EU and it is mandatory across Europe.

Important: all products which consume energy above the minimum level will not be able to be sold within the EU from 1 July 2016.