

CRIO Line CP 1 Door and 2 Drawer Freezer Counter, 265lt - No Top

ITEM # _____

MODEL # _____

NAME # _____

SIS # _____

AIA # _____



712197 (AK2F7AB)

1-door and 2-drawer freezer counter, -20-15°C, AISI 304, without worktop

Short Form Specification

Item No. _____

Internal and external doors, front and side panels in 304 AISI stainless steel. No worktop. N.1 door and n.2x1/2 drawers. Built-in refrigeration unit. Ventilated. Refrigerant R290. Extra insulation: 90mm body insulation to minimize energy dispersion. Digital control panel. Evaporator in aluminium. Completely automatic defrosting and automatic evaporation of defrost water obtained by hot gas. Temperature range: -15/-20°C. CFC and HCFC free. Feet in 304 AISI stainless steel, adjustable in height. Pre-arranged for drain pipe. Supplied with n.1x1/1GN Rilsan grid.

Main Features

- Digital control panel with temperature display.
- Forced air circulation for rapid cooling and an even temperature distribution.
- Compliant to CE requirements for safety.
- Anti-tilt runners accept GN1/1 trays and grids.
- Adjustable temperature range from -15°C to -20°C to suit all storage requirements.
- CFC and HCFC free (highly ecological refrigerant type: R290, - ecological gas in foam: cyclopentane).
- IQ Defrost - fully automatic defrost starts only when ice is actually building-up in the evaporator and adapts the defrosting duration to guarantee perfect ice removal while optimizing energy efficiency consumption.
- Adjustable temperature range from -15°C to -22°C.
- Large digital white-digit display with humidity selection button (3 preset level), internal temperature display and setting, manual activation of defrost cycle and turbo frost cycle (to rapidly cool warm loads).
- Equipped with Airflow system: forced air circulation system for rapid cooling and even temperature distribution within the cell.
- Tropicalized unit (43°C ambient temperature).
- Fitted with 90 mm thickness of cyclopentane insulation for best insulating performance (thermal conductivity: 0,020 W/m*K) and lowest environmental impact (GWP=3).
- 0mm clearance installation space: tower configuration cooling unit guarantee performance with frontal ventilation only; this unique solution allows installation against the wall or side by side with other appliances, even on the cooling unit side to maximize the use of kitchen space.
- Combination of doors and drawers to suit any configuration needed, with the possibility to change the configuration on site. Right cooling unit available on request.
- Frontal and easy access to all components in the cooling unit.
- Fully compliant HACCP digital control: when temperature exceeds critical limits, acoustic and visual alarms are activated. Up to two months of event are kept in memory.
- Anti-tilt runners accept GN 1/1 containers.
- Self closing stainless steel doors (< 90°).
- Certified safety CE requirements.
- Prearranged to fit RS485 port to facilitate connection to a remote computer and integrated HACCP systems.
- Hot gas automatic evaporation of defrost water.

Construction

- Access to all components from the front.
- Constructed in Stainless steel with Scotch Brite finish to meet the highest hygiene standards.
- Developed and produced in ISO 9001 and ISO 14001 certified factory.
- Mounted on Stainless steel adjustable legs to give 150 mm clearance for ease of cleaning.
- Rounded internal corners for ease of cleaning.
- 304 AISI stainless steel internal and external doors, front and side panels. Evaporator in aluminium.
- Pre-arranged for drain-pipe.
- 50 mm insulation thickness for energy saving.
- Fault code display.

APPROVAL: _____

- Interior base with rounded corners, pressed from a single sheet.
- Internal and external doors, front and side panels and removable worktop in AISI 304 Stainless steel.
- Removable triple-chamber balloon magnetic gasket to improve insulation and reduce energy consumption and ease of cleaning.
- Mounted on stainless steel feet to give 150 mm (-5/+50 mm) clearance for ease of cleaning the floor.
- Ease of cleaning and high hygiene standards thanks to the rounded internal corners, the easily removable runners, grids and air conveyors.
- Internal structure with 15 charging positions (3 cm pitch) available to host GN 1/1 grids, ensuring higher net capacity and a greater storage space.
- Extractable cooling unit to facilitate maintenance.
- IP21 protection index.
- Built-in refrigeration unit.
- Internal dimension of the drawers:
 - models with 2 1/2 drawers: 1st drawer (top drawer) 203x302x521 / 2nd drawer 223x302x521 (HxWxD)
 - models with 3 1/3 drawers: 1st drawer (top drawer) 98x302x521 / 2nd and 3rd drawers 118x302x521 (HxWxD)
 - models with 1/3+2/3 drawers: 1st drawer (top drawer) 98x302x521 / 2nd drawer 333x302x521 (HxWxD)

Included Accessories

- 1 of Kit 1/1 gray rilsan grid and 2 side runners PNC 881109 for refrigerated counters

Optional Accessories

- 2x1/2-drawer kit refrigerated counter PNC 881079
- 3x1/3-drawer kit refrigerated counter PNC 881080
- Worktop for ecostore HP refrigerated counters - PNC 881084 2 compartments
- Worktop and upstand for ecostore HP refrigerated counters - 2 compartments PNC 881087
- 1/1GN gray rilsan grid for refrigerated counters PNC 881107
- 2 side runners for 1/1 GN ecostore refrigerated counters PNC 881108
- Kit 1/1 gray rilsan grid and 2 side runners for refrigerated counters PNC 881109
- 1/1 GN plastic container, H=65 mm PNC 881110
- 1/1 GN plastic container, H=100 mm PNC 881111
- 1/1 GN plastic container, H=150 mm PNC 881112
- Lock for refrigerated counters with 2 compartments PNC 881152
- Kit 4 wheels, H=100 mm (2 with brakes) for refrigerated counters PNC 881191
- Kit 4 wheels, H=150 mm (2 with brakes) for 2&3 compartment refrigerated counters PNC 881193

Front

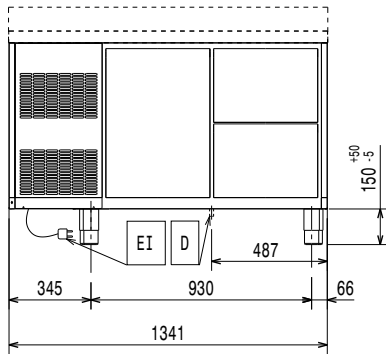

Side

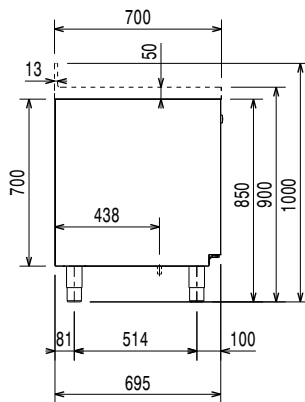

EI = Electrical inlet (power)

Top

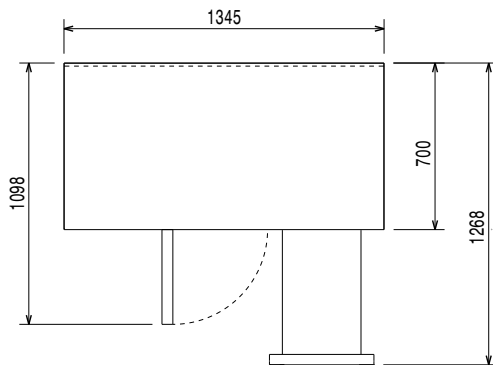

Electric

Supply voltage:	712197 (AK2F7AB)	220-240 V/1 ph/50 Hz
Electrical power max.:		0.49 kW
Defrost Power:		0.57 kW
Current consumption:		3.3 Amps
Plug type:		CE-SCHUKO
Energy consumption (min,default):		0 - 0 kW/h

Key Information:

Gross capacity:	290 lt
Net Volume:	149 lt
Door hinges:	Left
External dimensions, Width:	1341 mm
External dimensions, Height:	850 mm
External dimensions, Depth:	700 mm
Internal Dimensions (depth):	560 mm
Internal Dimensions (height):	550 mm
Internal Dimensions (width):	798 mm
Shipping volume:	1.08 m ³
Depth with doors open:	1110 mm
Height adjustment:	0/0 mm

Refrigeration Data

Control type:	Digital
Compressor power:	
Refrigerant type:	R290
GWP Index:	3
Refrigeration power:	569 W
Refrigeration power at evaporation temperature:	-30 °C
Refrigerant weight:	145 g
Min/Max internal humidity:	
Operating temperature min.:	-15 °C
Operating temperature max.:	-22 °C
Operating mode:	Ventilated

Product Information (EU Regulation 2015/1094)

Energy Class:	D
Yearly and daily energy consumption:	2190kWh/year - 6kWh/24h
Climate class:	Normal duty (cl.4)
Energy Efficiency Index (EEI):	67.38