

## CRIO Line CP 2 Door and 3x1/3 Drawer Refrigerated Counter, 420lt - No Top

ITEM # \_\_\_\_\_

MODEL # \_\_\_\_\_

NAME # \_\_\_\_\_

SIS # \_\_\_\_\_

AIA # \_\_\_\_\_



712637 (AJ3R7AAC)

2-door and 3x1/3-drawer refrigerated counter, -2+10°C, AISI 304, without worktop

### Short Form Specification

**Item No.** \_\_\_\_\_

Internal and external doors, front and side panels in 304 AISI stainless steel. No worktop. N.2 doors and n.3x1/3 drawers. Built-in refrigeration unit. Ventilated. Refrigerant R134a. Extra insulation: 90mm body insulation to minimize energy dispersion. Digital control panel. Evaporator in aluminium. Completely automatic defrosting and automatic evaporation of defrost water obtained by hot gas. Temperature range: -2+10°C. CFC and HCFC free. Feet in 304 AISI stainless steel, adjustable in height. Pre-arranged for drain pipe.

APPROVAL: \_\_\_\_\_

### Main Features

- Adjustable temperature range from -2 °C to +10 °C to suit meat, fish and dairy storage requirements.
- Large digital white-digit display with humidity selection button (3 preset level), internal temperature display and setting, manual activation of defrost cycle and turbo frost cycle (to rapidly cool warm loads).
- Equipped with Airflow system: forced air circulation system for rapid cooling and even temperature distribution within the cell.
- Tropicalized unit (43°C ambient temperature).
- Fitted with 90 mm thickness of cyclopentane insulation for best insulating performance (thermal conductivity: 0,020 W/m\*K) and lowest environmental impact (GWP=3).
- 0mm clearance installation space: tower configuration cooling unit guarantee performance with frontal ventilation only; this unique solution allows installation against the wall or side by side with other appliances, even on the cooling unit side to maximize the use of kitchen space.
- IQ Defrost - fully automatic defrost starts only when ice is actually building-up in the evaporator and adapts the defrosting duration to guarantee perfect ice removal while optimizing energy efficiency consumption.
- Combination of doors and drawers to suit any configuration needed, with the possibility to change the configuration on site. Right cooling unit available on request.
- Frontal and easy access to all components in the cooling unit.
- Fully compliant HACCP digital control: when temperature exceeds critical limits, acoustic and visual alarms are activated. Up to two months of event are kept in memory.
- Anti-tilt runners accept GN 1/1 containers.
- Self closing stainless steel doors (< 90°).
- Certified safety CE requirements.
- Prearranged to fit RS485 port to facilitate connection to a remote computer and integrated HACCP systems.
- Hot gas automatic evaporation of defrost water.

### Construction

- Interior base with rounded corners, pressed from a single sheet.
- Ease of cleaning and high hygiene standards thanks to the rounded internal corners, the easily removable runners, grids and air conveyors.
- Removable triple-chamber balloon magnetic gasket to improve insulation and reduce energy consumption and ease of cleaning.
- Internal structure with 15 charging positions (3 cm pitch) available to host GN 1/1 grids, ensuring higher net capacity and a greater storage space.
- Internal and external doors, front and side panels and removable worktop in AISI 304 Stainless steel.

- Mounted on stainless steel feet to give 150 mm (-5/+50 mm) clearance for ease of cleaning the floor.
- Built-in refrigeration unit.
- Developed and produced in ISO 9001 and ISO 14001 certified factory.
- Fault code display.
- CFC and HCFC free (ecological refrigerant type: R134a, - gas in foam: cyclopentane).
- Extractable cooling unit to facilitate maintenance.
- IP21 protection index.
- Internal dimension of the drawers:
  - models with 2 1/2 drawers: 1st drawer (top drawer) 196x302x521 / 2nd drawer 198x302x521 (HxWxD)
  - models with 3 1/3 drawers: 1st and 2nd drawers (top and central drawer) 99x302x521 / 3rd drawers 103x302x521 (HxWxD)
  - models with 1/3+2/3 drawers: 1st drawer (top drawer) 99x302x521 / 2nd drawer 295x302x521 (HxWxD)

### Included Accessories

- 2 of Kit 1/1 gray rilsan grid and 2 side runners PNC 881109 for refrigerated counters

### Optional Accessories

- 1/1GN gray rilsan grid for refrigerated counters PNC 881107
- 2 side runners for 1/1 GN ecostore refrigerated counters PNC 881108
- Kit 1/1 gray rilsan grid and 2 side runners for refrigerated counters PNC 881109
- 1/1 GN plastic container, H=65 mm PNC 881110
- 1/1 GN plastic container, H=100 mm PNC 881111
- 1/1 GN plastic container, H=150 mm PNC 881112
- Worktop for ecostore refrigerated counters - 3 compartments PNC 881125
- Worktop and upstand for ecostore refrigerated counters - 3 compartments PNC 881128
- 2-drawer kit refrigerated counters PNC 881179
- 3x -drawer kit for refrigerated counters PNC 881186
- 1/3 and 2/3 bottle drawer kit for refrigerated counters PNC 881187
- Lock for refrigerated counters (3 compartments) - H650 PNC 881189
- Kit 4 wheels, H=100 mm (2 with brakes) for refrigerated counters PNC 881191
- Kit 4 wheels, H=150 mm (2 with brakes) for 2&3 compartment refrigerated counters PNC 881193

**Front**

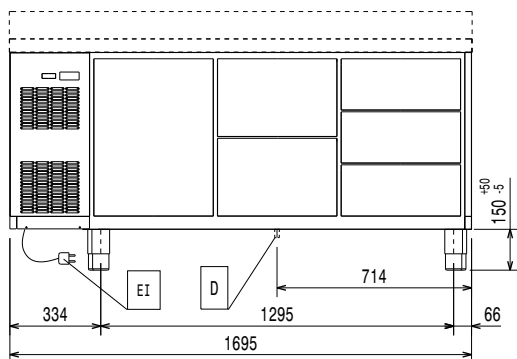

**Side**

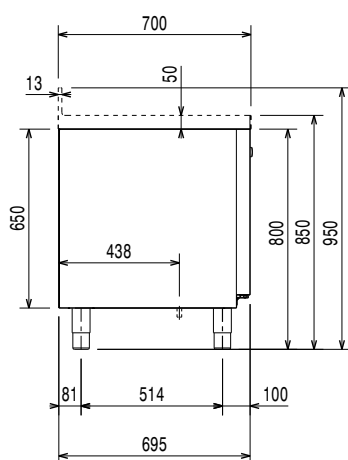

EI = Electrical inlet (power)

**Top**

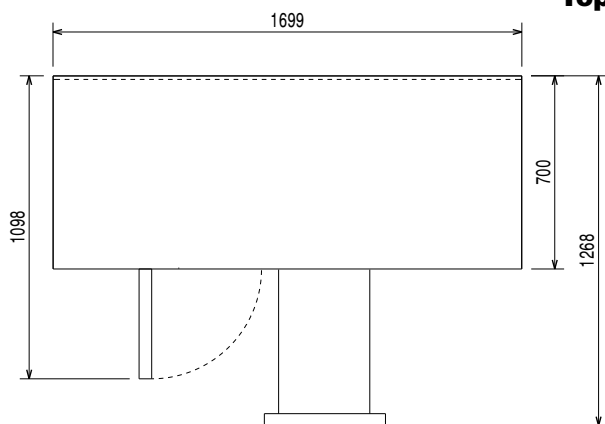

### Electric

Supply voltage:	712637 (AJ3R7AAC)	220-240 V/1 ph/50 Hz
Electrical power max.:		0.22 kW
Defrost Power:		0.27 kW
Current consumption:		1.7 Amps
Plug type:		CE-SCHUKO
Energy consumption (min,default):		0 - 0 kW/h

### Key Information:

Gross capacity:		
Net Volume:		202.4 lt
Door hinges:		1 Left+1 Right
External dimensions, Width:		1695 mm
External dimensions, Height:		800 mm
External dimensions, Depth:		700 mm
Internal Dimensions (depth):		560 mm
Internal Dimensions (height):		510 mm
Internal Dimensions (width):		1252 mm
Shipping volume:		1.36 m <sup>3</sup>
Depth with doors open:		1110 mm
Height adjustment:		-5/50 mm

### Refrigeration Data

Control type:		
Compressor power:		0.25 hp
Refrigerant type:		R134a
GWP Index:		1300
Refrigeration power:		358 W
Refrigeration power at evaporation temperature:		-10 °C
Refrigerant weight:		120 g
Min/Max internal humidity:		40/85
Operating temperature min.:		-2 °C
Operating temperature max.:		10 °C
Operating mode:		Ventilated

### Product Information (EU Regulation 2015/1094)

Energy Class:		C
Yearly and daily energy consumption:		829kWh/year - 2.27kWh/24h
Climate class:		Normal duty (cl.4)
Energy Efficiency Index (EEL):		35.93