

Planetary Mixers

Planetary Mixer for Bakery, 40 lt. - Electronic + hub

ITEM # _____

MODEL # _____

NAME # _____

SIS # _____

AIA # _____

600272 (MBE40AB)

40 lt Planetary Mixer, bowl detection device and SOLID BPA free safety screen, with electronic speed variation. Equipped with spiral hook, paddle, whisk and H type accessory hub. Suitable for bakery preparation

Short Form Specification

Item No.

Suitable for bakery and pastry making, for kneading, blending and whipping operations. Reinforced body for heavy duty use with 18/8 (AISI 302) 40 litre capacity stainless steel bowl. Reinforced transmission and powerful asynchronous motor (2200W) with 3 fixed speeds (40,80,160 rpm) and electronic variable speed (from 30 to 175 rpm). Bowl detection device allows the mixer to switch on only when the bowl and the safety screen are properly installed and positioned together. Water proof (IP55) and flat touch button control panel with a timer from 0-59 min. Pivoting and removable wire safety screen. Kneading: speed 1 or 2 with hook; Blending: speed 2 with paddle; Whipping: speed 3 with whisk. Equipped with accessory drive hub type H (accessories are not included). Supplied with 3 tools: spiral hook, paddle and reinforced whisk.

Main Features

- Professional beater mixer designed to withstand the strong demands of bakery and pastry making.
- Delivered with:
 - Spiral Hook, Paddle, Wire Whisk and Mixing Bowl for 40 lt.
 - Accessory drive hub (accessories are not included).
- Kneading speed: "1" with hook.
- Mixing speed: "2" with paddle.
- Emulsifying speed: "3" with whisk.
- Wire safety screen fitted with a removable chute to add products while working, thus ensuring operator safety.
- Pivoting and removable wire safety screen for easier and better cleaning.
- Raising and lowering of the bowl controlled by lever with an automatic locking of the bowl when in the raised position.
- Waterproof touch button control panel with timer, speed setting and display.
- Safety device will automatically stop the machine when the bowl is lowered.
- Maximum capacity (flour, with 60% of hydration) 10 kg.
- Solid BPA-free safety screen, covering the stainless steel wire one, limits the flour and unsafe dust particles when used in bakery and pastry preparation.
- Bowl detection device allows the mixer to switch on only when the bowl and the solid safety screen are properly installed and positioned together.

Construction

- Reinforced body, feet and transmission for heavy duty operations.
- 302 AISI Stainless steel bowl - 40 lt. capacity.
- Electronic speed variator (10 speeds available from 30 to 175 rpm)
- 3 fixed speeds: 40, 80 and 160 rpm.
- Water protected planetary system (IP55 electrical controls, IP23 overall machine).
- Power: 2200 watts.
- Aluminium accessory hub positioned on the left side of the head of the planetary mixer.
- The solid safety screen and the stainless steel wire structure are both removable and dismantled for cleaning and are dishwasher safe.
- Adjustable feet to perfect stability.

Included Accessories

- 1 of Bowl 40 lt for MB/MBE models PNC 650128
- 1 of Spiral Hook 40 lt for MB/MBE models PNC 653092
- 1 of Paddle 40 lt for MB/MBE models PNC 653093
- 1 of Whisk 40 lt, reinforced (for heavy duty use) for MB/MBE planetary mixers PNC 653127

APPROVAL: _____

Optional Accessories

- 20 lt reduction kit (bowl, spiral hook, paddle, whisk) for 40 lt planetary mixers - bakery models PNC 650126
- Bowl 40 lt for MB/MBE models PNC 650128
- Bowl scraper 40 lt PNC 650186
- Spiral Hook 40 lt for MB/MBE models PNC 653092
- Paddle 40 lt for MB/MBE models PNC 653093
- Fine Whisk 40 lt for MB/MBE planetary mixers (for emulsions) PNC 653094
- Whisk 40 lt, reinforced (for heavy duty use) for MB/MBE planetary mixers PNC 653127
- Puree strainer for H hub supplied with 1 screw and 3 grids of 1.5, 3 and 6 mm PNC 653187
- Vegetable cutter, attachment type H, disconnectable drive, for planetary mixers PNC 653225
- Bowl trolley for 40/60/80 lt planetary mixers PNC 653585
- Aluminium external support for 70 mm meat mincer (includes tray and pusher) - H HUB - To be combined with a meat mincer kit PNC 653720
- Aluminium meat mincer kit 70 mm - Enterprise cut, includes blade (3 discs, diam. 4.5 - 6 and 8 mm) PNC 653721
- Stainless steel meat mincer kit 70 mm - Enterprise cut, includes blade (3 discs, diam. 4.5 - 6 and 8 mm) PNC 653722
- Stainless steel meat mincer kit 70 mm - 1/2 Unger cut, includes blade (4 discs, diam. 0, 3 - 4.5 and 8 mm) PNC 653723
- Aluminium external support for 82 mm meat mincer (includes tray and pusher) - H HUB - To be combined with a meat mincer kit PNC 653724
- Stainless steel meat mincer kit 82 mm - Enterprise cut, includes blade (3 discs, diam. 4.5 - 6 and 8 mm) PNC 653725
- Aluminium meat mincer kit 82 mm - Enterprise cut, includes blade (3 discs, diam. 4.5 - 6 and 8 mm) PNC 653726
- Stainless steel meat mincer kit 82 mm - 1/2 Unger cut, includes blade (4 discs, diam. 0, 3 - 4.5 and 8 mm) PNC 653727

Front

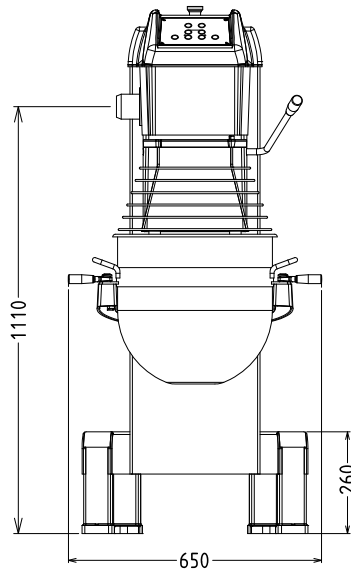
Electric
Supply voltage:

600272 (MBE40AB) 200-240 V/1N ph/50/60 Hz

Electrical power max.:

2.2 kW

Total Watts:

2.2 kW

Capacity:
Performance (up to):

10 - kg/Cycle

Capacity:

40 litres

Key Information:
External dimensions, Width: 655 mm

External dimensions, Height: 1370 mm

External dimensions, Depth: 850 mm

Shipping weight: 195 kg

Cold water paste: 10 kg with Spiral hook

Egg whites: 70 with Whisk

Side

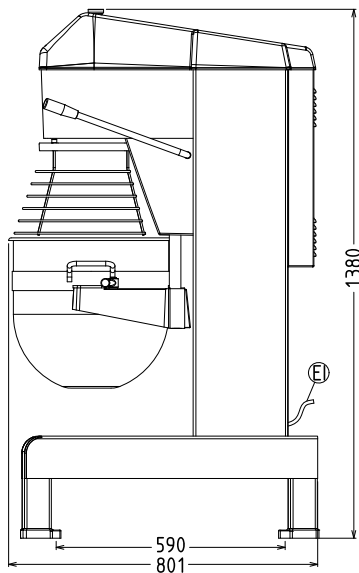

EI = Electrical inlet (power)

Top

